

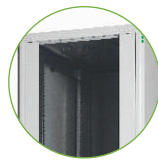

Nitrotel
Manufacturing
Low Voltage Products & Fiber Optic

SPARK SERIES FREE STAND CABINETS

Nitrotel Spark Series offer a select line of cabinet solutions that support and protect network devices, rack-mount servers and other applications in telecommunication equipment rooms, data centers and enterprise cabling applications, while providing an optimized space utilization.

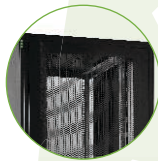

KEY FEATURES AND BENEFITS

- Wide range of cabinets designs and industry-standard sizes available for specific thermal applications.
- Two configurations support front-to-rear airflow or noise reduction.
- Innovative vertical split side panels provide superior access to network devices and cabling.
- Fully compatible with 19" rack-mount equipment.
- Exclusive Flat Pack maximizes space utilization for transportation and storage.

PRODUCT DATA SHEET

Spark Series Cabinets

Available in a comprehensive set of industry-standard sizes, Spark Series Cabinets features two configurations that meet most application requirements:

1. Spark Network cabinets with shatter-proof glass front doors and solid rear doors, provides an ideal noise control for structured cabling systems in office environments, call centers and computer rooms, while they can also be deployed in small and medium-size data centers.

2. Spark Server cabinets with perforated front and rear doors allow an exceptional front-to-rear airflow for hot aisle/cold aisle applications in any medium or large size data center. Honeycomb style perforated doors provide maximum exhaust of hot air away from the cabinet to minimize operating costs.

Both configurations feature vertical split side panels for comfortable easy access to the installed devices, cable openings in the top panels that are large enough for high-amperage cables, bottom plates with sliding cable entry paths to block dust inlet and silk-screened adjustable mounting rails to easily count U-marking from top to down/down to top.

SPECIFICATIONS

	Spark Network	Spark Server
Includes	Welded front and rear monoblock steel frames, Increase high rigidity	
	Silk-screen equipment mounting rails, two pairs	
	4 fans module. Noise 46db, Air Flow 138/162 m ³ /Hr 82/95 CFM	
	Grounding/bonding system and ground lug	
	Leveling feet	Leveling feet and casters
Equipment Space	See Height, Width and Depth tables under Ordering Information/Dimensions	
Load Capacity	Up to 3000 lb (1360 kg) static load rating to support high-density applications and multiple blade servers	
Certifications	EN 61587 -1:2012 Mechanical Structures for Electronic Equipment, IEC 197-1, 19" Mounting, IEC 297-2 Overall Cabinet Dimensions, ISO 14001, EIA-310-E compliant, ISO 9001-2008, TSE certificate, RoHS Compliant.	
Structure Material	UL Listed E486214	
Finish	Steel frame, rails, side panels, bottom plate and roof panel.	
Environment	Electrostatic powder coat paint on frame, doors, bottom plate, roof panel and side panels in Black RAL 9005 or Gray RAL 7035	
Construction	For indoor use only, in environmentally controlled areas, not harsh environments.	
	Protection index: IP30 According to EN 61587-1/IEC 60529	
Doors/Lock Kits	Welded/bolted frame	
	Mounting rails bolt to frame	
	Tempered glass front door	Perforated front door
	Solid rear door	Choice of solid or double perforated rear door
	Shatter-proof glass front door	Perforated area is 80% or 63% open
	Solid rear door includes a barrel lock	Double rear door includes 3 points lock system
	Front door opens to 120°	
	Rear door opens to 120°	Rear double door opens to 120°
	Hinge pins allow easy removal during maintenance	
	Reversible to open from the right or left, must change swing lock position	
	Interchangeable front or rear	
	Swing handle with keyed lock	
Side Panels	Solid, two-piece panels (vertical split design)	
	Recessed spring-loaded latch with barrel lock, keyed to match doors	
	Panels with cable openings and/or perforations available upon client request	
Top Panel	Standard panel is one-piece solid panel. Top panel shall be compatible with 4-fans cooling unit for D: 600/800mm cabinets and 6-fans cooling unit for D: 1000mm or deeper.	
Bottom Panel	Cutout opening is 300 mm x 56mm, wide enough for large amperage cables Standard panel is one-piece solid panel. Panel shall have sliding cable entry paths with dimensions 300mm x 125mm (1ea for 600mm x 600mm, 2ea 600mm x 800mm and 600mm x 1000mm)	
Grounding/Bonding	Side panels and doors are electrically bonded to the cabinet frame Optional copper grounding bar for mounting rails upon customer request	
Equipment Support	Two pairs of mounting rails	
	Adjustable depth, horizontal joint rails front-to-back	
	44.45mm U spacing, silk-screen market and number on mounting rails	
	EIA-310-E Universal 15.9mm-15.9mm-12.7mm vertical hole spacing	
	Square-punched mounting holes accept standard cage nuts	

Spark Series knock-down cabinets come in a compact flat-pack design which allows an easier handling of the cabinets into places with difficult access, such as halls, narrow entrances, stairs or elevator doors.

Create a cabinet solution that fits your needs by selecting Nitrotel compatible shelves, PDUs and cable management accessories. Contact Nitrotel Technical Support for configuration assistance.

PRODUCT DATA SHEET

Spark Series Cabinets

Front Door

The front door is designed to provide security with lock mechanism and aesthetic view together. Spark series network cabinets have full-length smoked and shatter proof glass front door with left & right frames, while Spark series server cabinets have 80% perforated front door. Both options easily rotate to the left or right directions by special spring hinge. 3-points and single point locking systems are available upon customer requirements.

Side Panel

Solid metal side panels offer easy access with lockable and removable structure. Completed with 2 pcs of sliding latches and 1 pc barrel lock.

Bottom Plate

Bottom plate provides easy cable management with its large internal volume cable entry path with sliding cover 300x125mm (2 cable entry paths for depth: 800mm & 1000mm cabinets)

Rear Door

Single opening rear door with spring hinge and barrel lock for network cabinet & double opening rear door with 3-points locking system for server cabinets.

Front and rear welded frames

Welded main carrier frames provide an excellent robustness for a comfortable storage. Each frame has a total of 24 folds, which increases structural stability. Spark series rack cabinets provides a safe housing for your network. Its steel construction supports a high load carrying capacity up to 1360kg

19" Mounting Angles

The vertical mounting rails are adjustable throughout the entire depth of the cabinet and have very high carrying capacity with 1.5mm thickness. Silk-screen mounting rails are providing ability to count U-Marking from top to down & down to up for easy device installation

80% perforated Metal Door



63% perforated Metal Door



Solid Metal Door



Glazed Door



80% perforated Metal Door



63% perforated Metal Door



Solid Metal Door



PRODUCT DATA SHEET

Spark Series Cabinets D:600

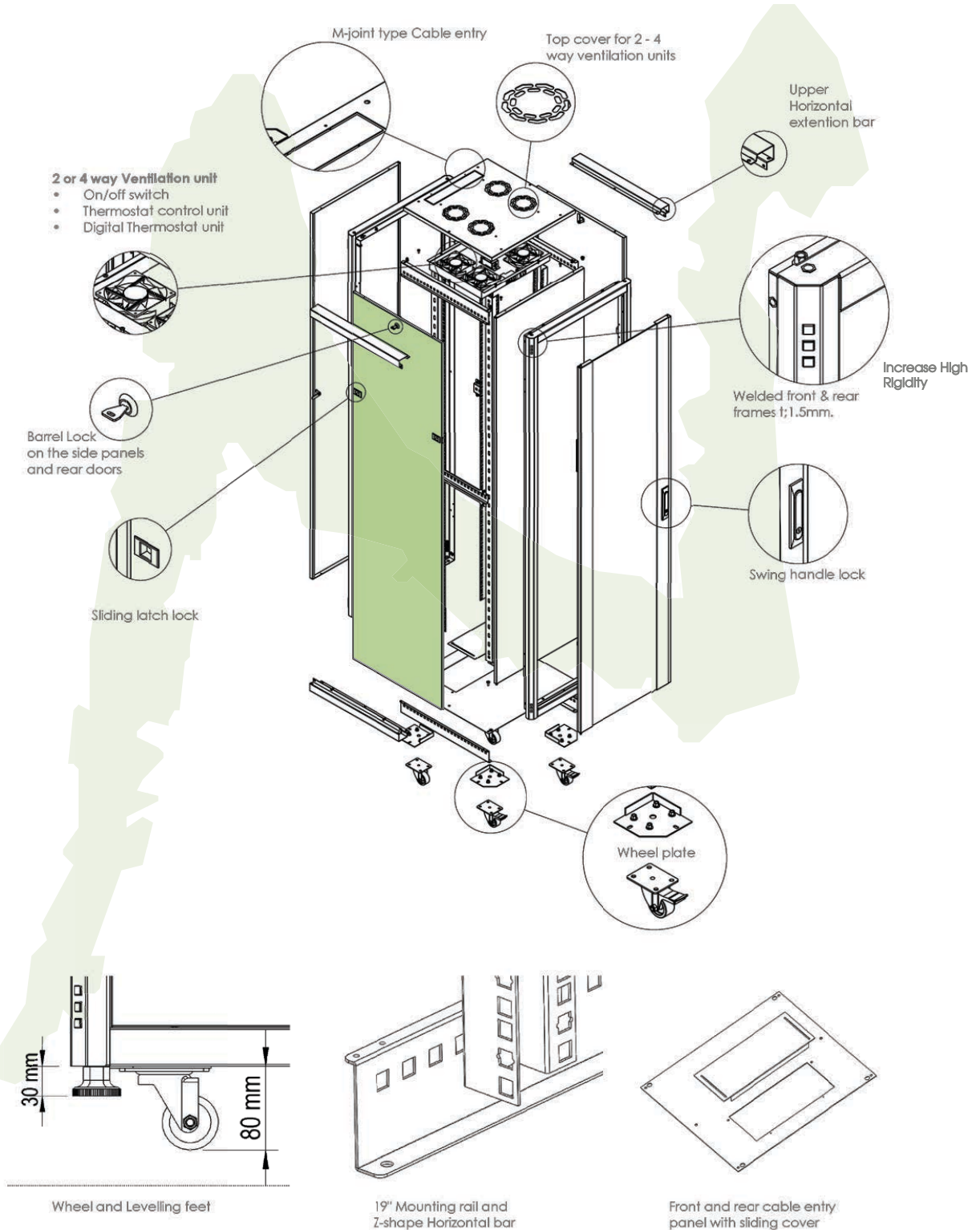

PRODUCT DATA SHEET

Spark Series Cabinets D:800, D:1000, D:1100 & D:1200

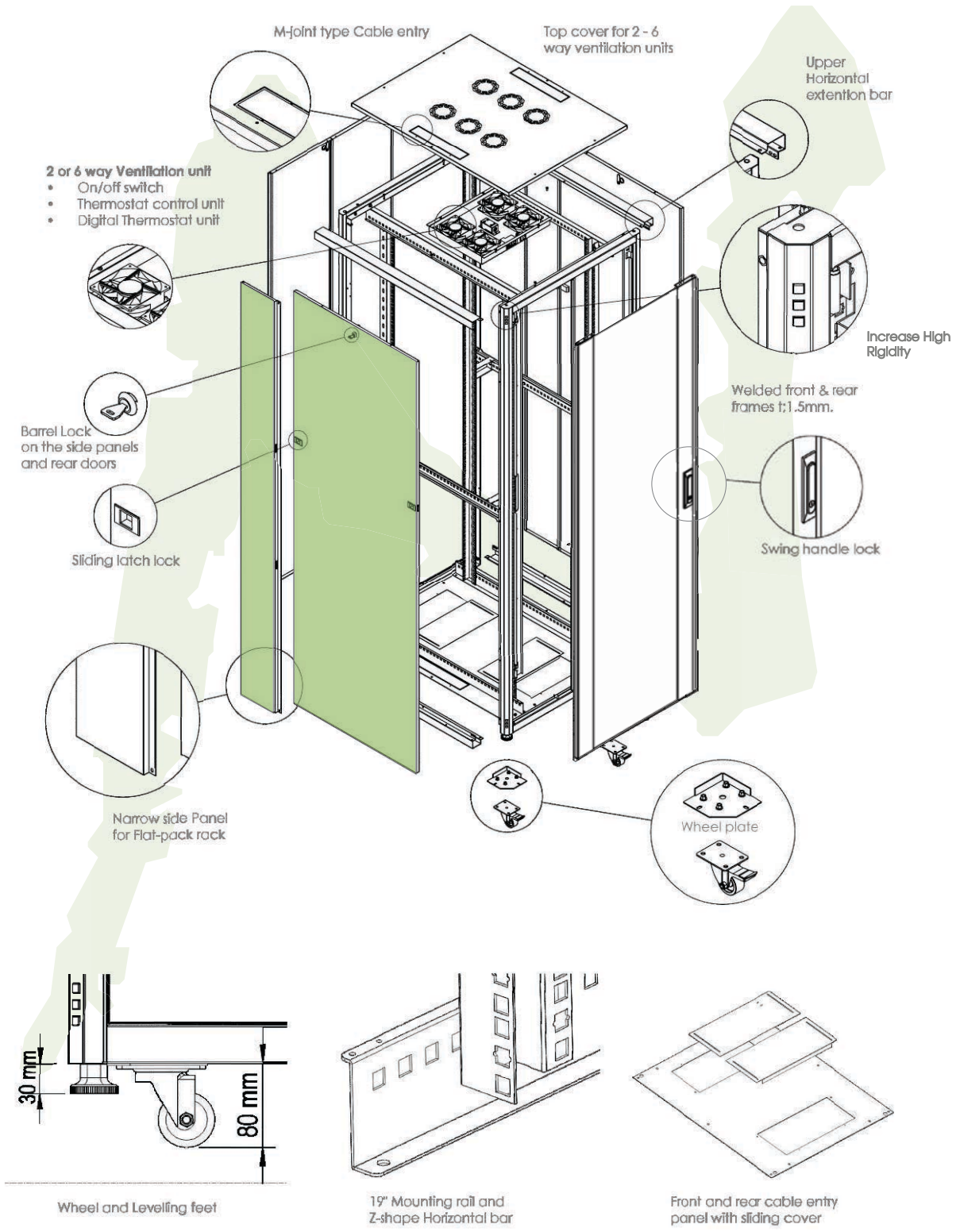

PRODUCT DATA SHEET

Spark Cabinet: W:600 - D:1100

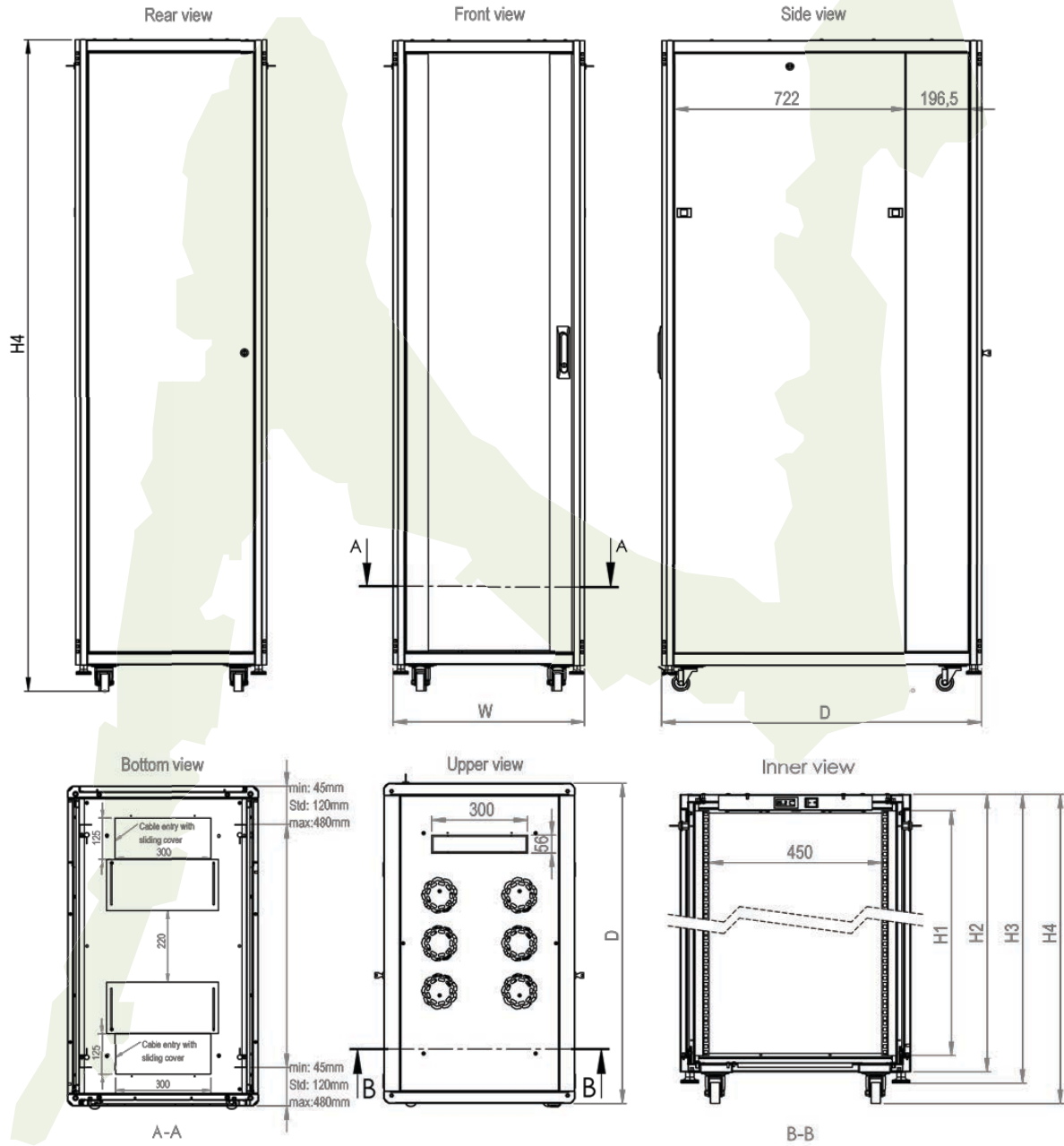

PRODUCT DATA SHEET

Spark Cabinet: W:800 - D:1000

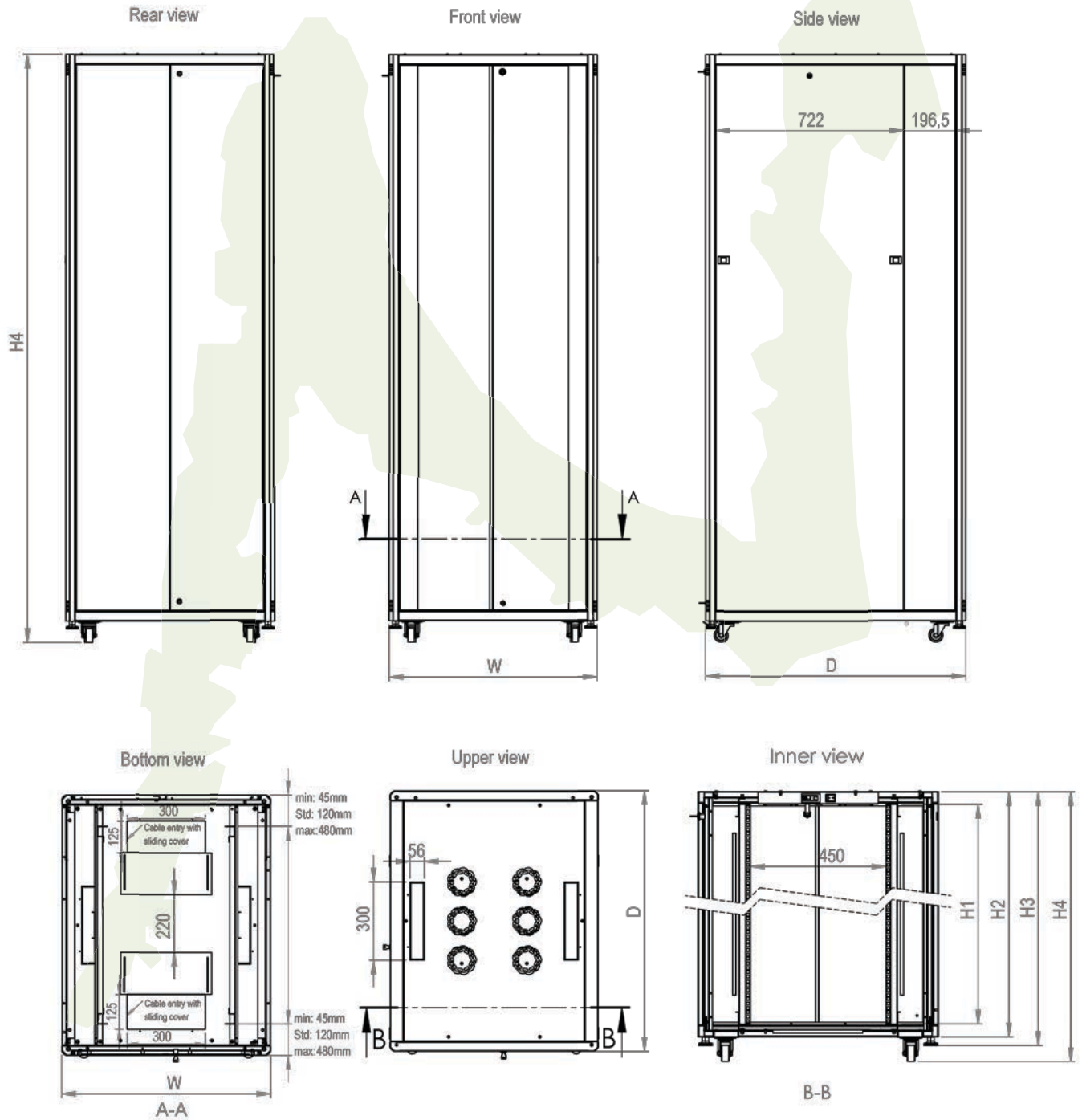

PRODUCT DATA SHEET

Spark Cabinet: W:800 - D:1100

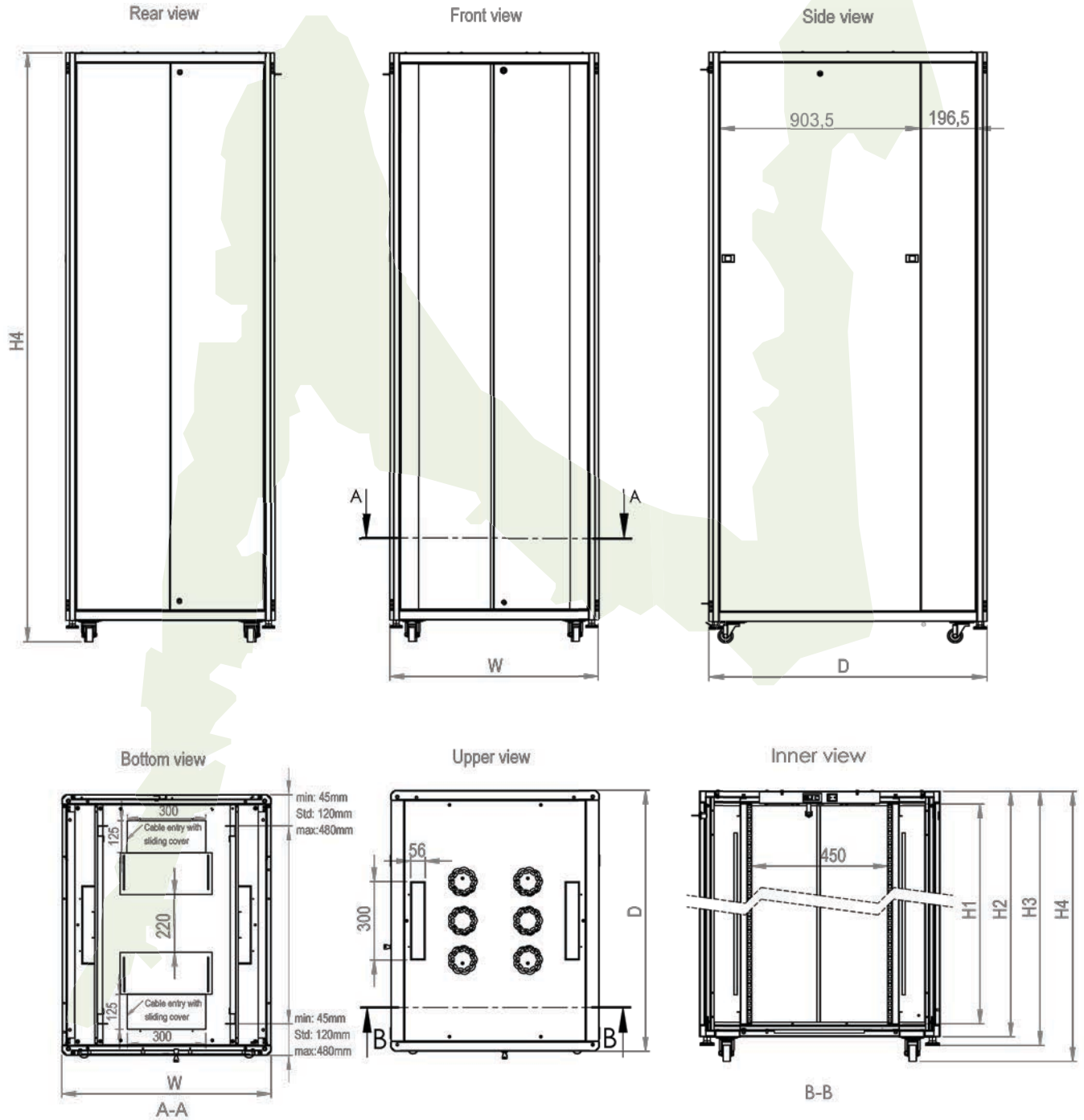

PRODUCT DATA SHEET

Spark Cabinet: W:800 - D:1200

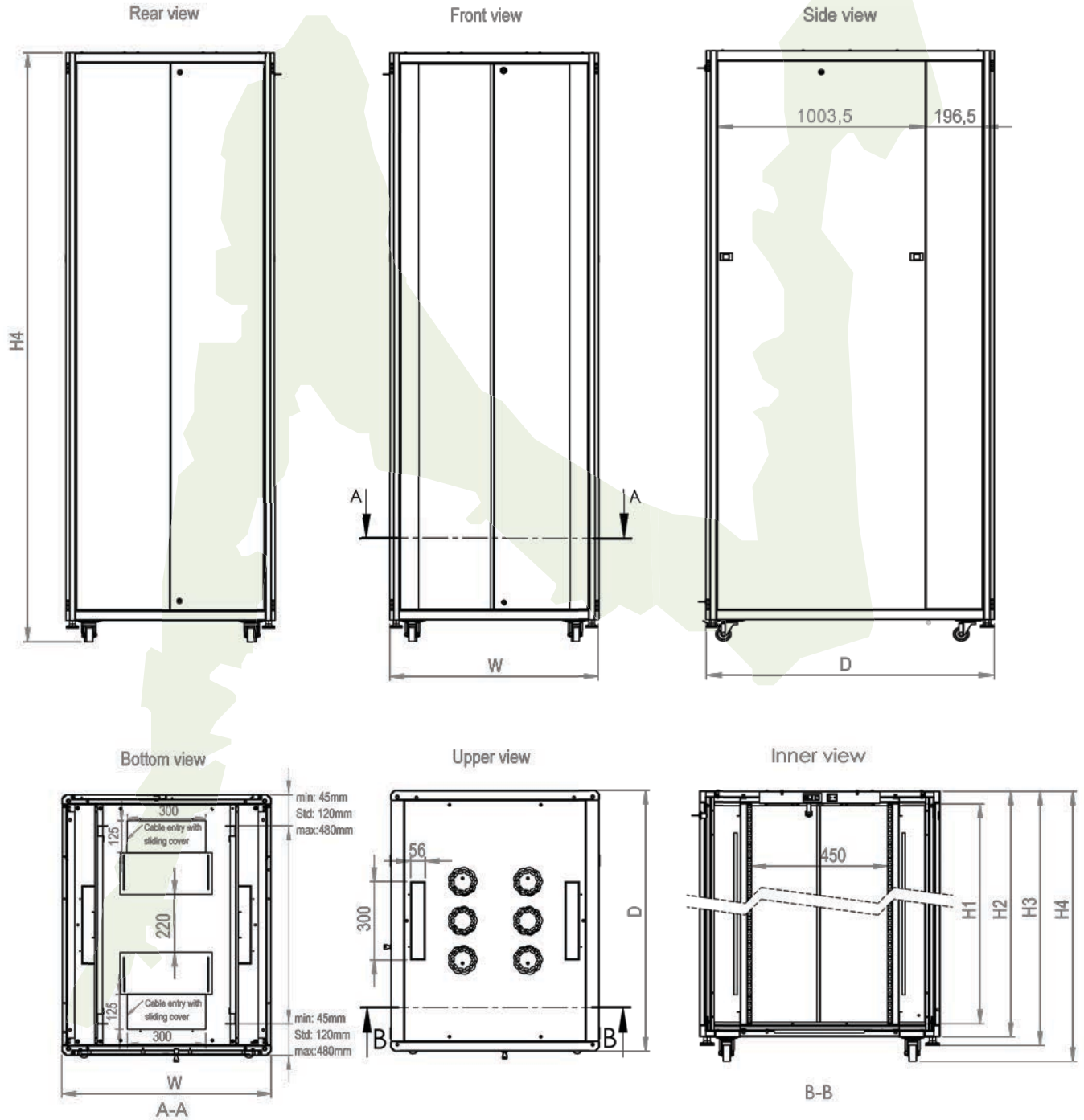

PRODUCT DATA SHEET

Spark Series Cabinets

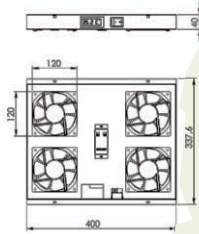

Quick-change fan trays that can be accessed without removing the cabling or the device from the rack

Spark serie's roof panel has been designed for ventilation module which can be detached by removing 4 pcs screws from the top in case of maintenance or replacement needs.

Standards: ISO 9001, CE (89/336/EEC EMC, 73/23/EEC LVD 2006/95/EC), RoHS", Noise 46db , Air FlowM3/Hr 138/162 CFM 82/95.

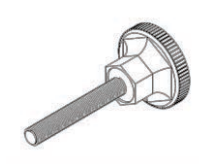
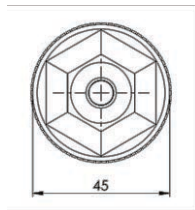
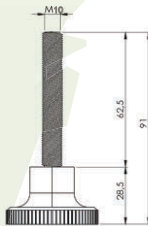
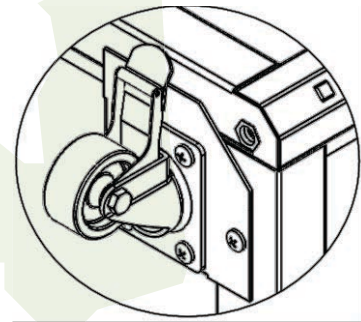
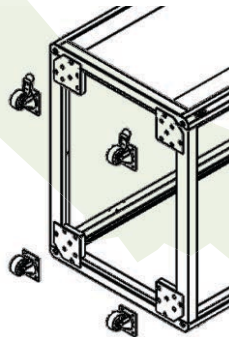
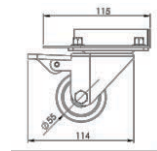
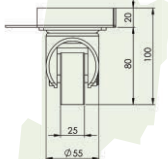
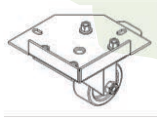
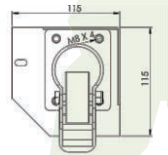
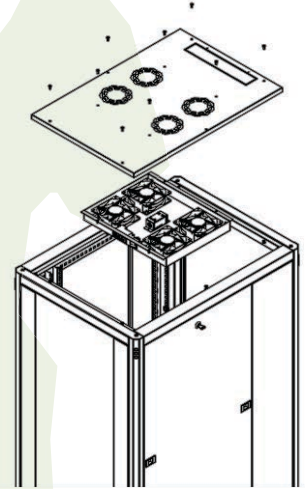

CASTER SET & LEVELLING FEET		
ITEM	DESCRIPTION	INCLUDED IN:
NTCFB30	Spark cabinet castor set of 2 pcs. lockable and rotatable	Server cabinets
NTCF30	Spark cabinet castor set of 2 pcs. rotatable	Server cabinets
NTLFM10	Levelling feet for cabinets (M10)	Server & Network cabinets

PRODUCT DATA SHEET

Spark Series Cabinets

Vertical cable management panel

Vertical cable management panel is designed for higher density cabling and connectivity system applications and also offers ease, density, availability, affordability and scalability together.

- Compatible with only width: 800mm rack cabinets (included)
- The vertical cable management panels are adjustable throughout the entire depth of the cabinet with mounting rails.
- Openings between fingers align with each U on the mounting rear
- Hinged cover included with managers, cover snaps closed to secure cables.
- Material: Steel panels, plastic guides and latches.
- Finish: Black or Grey; latches are black.
- Plastic finger type cable managers available upon request.

This well-engineered cable management system offers you a high level of versatility and flexibility for routing and organizing high density cable bundles, KVM and power cables.

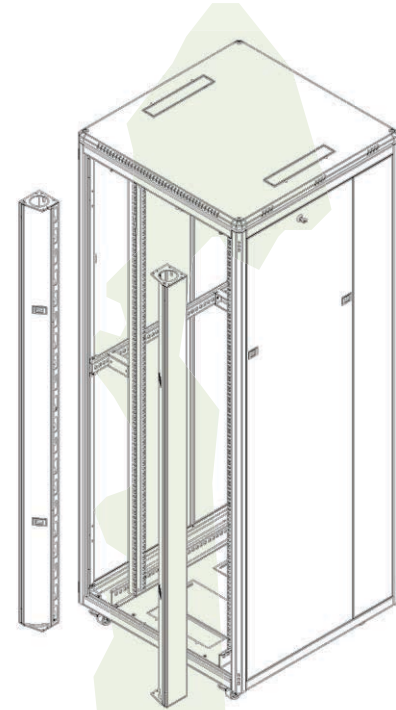

Harmonization system codes—HS code

- 8538.10.00.00.00 : Rack cabinet without accessories
- 85.37.10.99.00.19 : Rack cabinet with accessories

Type of shipping

- Assemble/ Flat-pack

Load carrying capacity

- 1360kg / 3000lbs

Surface treatment

- On flat metal surfaces, there must be 85±5 micron paint thickness and must be tested according to IEC 60068-2-1, IEC 60068-2-2, IEC 60068-2-30, IEC 60068-2-42, IEC 60068-2-43, IEC 60068-2-49, IEC 60068-2-11

Standard color

- Ral: 7035 Light gray/ Ral:9005 Black

Shipment configuration

- Front door with glass or perforations 1 set
- Rear door 1ea
- Side panel 2pcs (D: 600mm) or 4 pcs (D: 800 & 1000mm)
- Bottom extension parts 2 pcs
- Upper extension parts 2pcs
- Welded metal frame 2pcs
- C-type rails 2pcs
- 19inch Mounting rail 4pcs
- Bottom plate 1ea
- Roof panel 1ea
- Grounding wire set 1ea
- Screw set 1set
- Swing handle lock 1ea
- Leveling feet 1set - 4pcs
- Casters 1set - 4pcs (server cabinets only)

Packaging

- Wooden pallet 1 ea (ISPM heat treated application)
- Stretch wrapping
- Cardboard
- Plastic strip
- Product label

